

STRENGTH OF MECHANICAL CONSTRUCTIONS

PROJECT – ANALYSIS OF A CURVED BAR (2026)

The project deals with an analytical determination of the curved bar deformation as well as the description of stress distribution along the cross-section of the bar.

A curved bar presented in figure below is clamped at one end (point A) and loaded with horizontal force F_x and vertical force F_y at the second end (point B). The radius of the centre line of the bar is R_0 . The rectangular cross section has dimensions h and b . The mechanical properties of the material of the bar are: Young's modulus $E = 2 \cdot 10^5$ MPa, Poisson's ratio $\nu = 0.3$. Other data are given in the table (next page). A negative value of the force means that it is directed opposite to the vector in the figure.

1. Treating the bar as a thin curved bar loaded with the force F (neglect the influence of curvature, take into account only the energy due to bending moment) :
 - (a) plot distribution of internal forces as functions of an angle φ ($N(\varphi), V(\varphi), M(\varphi)$),
 - (b) determine the vertical displacement of point B,
2. Treating the bar as a thick curved bar loaded with the force F :
 - (a) determine the internal forces in the cross section D-D
 - (b) determine the position of the neutral line,
 - (c) determine the value of normal stress at inner and outer surface of the bar (for $\varphi = \pi/2$),
 - (d) plot the stress distribution through the cross section of the bar (for $\varphi = \pi/2$),

Guidelines for the preparation of project

- first page is a title page (where, what, who, when)
- start with defining the problem based on the provided information – drawing, what to do, etc.
- A4 paper printed on both sides (printout or handwriting)
- all pages must be clipped together
- calculations should be carried on using symbolic notations; values of parameters should be substituted after the final symbolic solution is known
- be sure that the project is readable

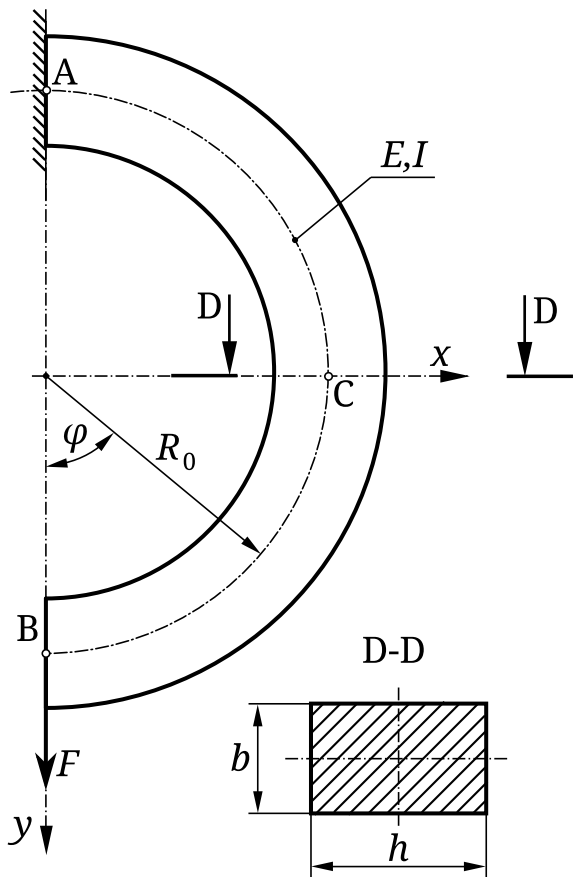

Data for the project

| No | F [kN] | R_0 [mm] | h [mm] | b [mm] |
|----|-------------|---------------|-------------|-------------|
| 1 | 10 | 80 | 80 | 40 |
| 2 | 8 | 60 | 60 | 30 |
| 3 | -8 | 50 | 50 | 50 |
| 4 | -10 | 90 | 80 | 60 |
| 5 | 12 | 80 | 70 | 30 |
| 6 | 11 | 70 | 60 | 40 |
| 7 | 5 | 40 | 40 | 20 |
| 8 | 8 | 65 | 60 | 40 |
| 9 | 16 | 90 | 100 | 50 |
| 10 | -12 | 100 | 100 | 60 |
| 11 | 7 | 75 | 80 | 50 |
| 12 | -15 | 70 | 80 | 60 |
| 13 | -10 | 50 | 60 | 50 |
| 14 | 14 | 70 | 70 | 70 |
| 15 | 9 | 80 | 90 | 70 |
| 16 | 7 | 55 | 60 | 50 |
| 17 | -12 | 100 | 80 | 60 |
| 18 | 10 | 90 | 70 | 60 |
| 19 | 8 | 40 | 40 | 20 |
| 20 | -12 | 100 | 90 | 60 |
| 21 | 16 | 90 | 100 | 50 |
| 22 | -16 | 120 | 100 | 60 |
| 23 | 10 | 60 | 80 | 40 |